

# Model Ser.80 (DT)

## DOUBLE GATE KNIFE GATE VALVE

The Series 80 (DT) model knife gate valve is a bi-directional valve widely used in the Pulp and Paper industry (paper recycling) and especially designed to handle high concentrated or contaminated media. In the open position, both gates are retracted into the body, assuring full flow. When the gates close, they push stock and contaminants as staples, wires, etc., out of the body and back into the flow. As a result of this double gate design, the stroke time of these valves is half of that of the conventional valves. All components subject to wear can be easily replaced

### Sizes (DN)

4in/100mm to DN 24in/600mm  
Larger diameters on request

### Working pressure and temperatures

4in/100mm to 10in/250mm : 150psi/ 10 bar  
12in/300mm to 16in/400mm: 90psi/ 6 bar  
18in/450mm: 75psi/ (5 bar)  
20in/500mm to 24in/600mm : 60psi/ 4 bar

Carbon steel: 14°F (-10°C) / 176°F (80°C)  
AISI 316: -4°F (-20°C) / 176°F (80°)

### Standard flange drilling

ASME B16.5 (class 150)  
EN 1092 PN10  
Other flange drillings available on request

### Directives

For EU Directives and other Certificates please see the document: Directives & Certificates Compliance - Knife Gate Valves -Catalogues and Datasheets

### Testing

All valves are tested prior to shipping in accordance with the standard EN-12266-1

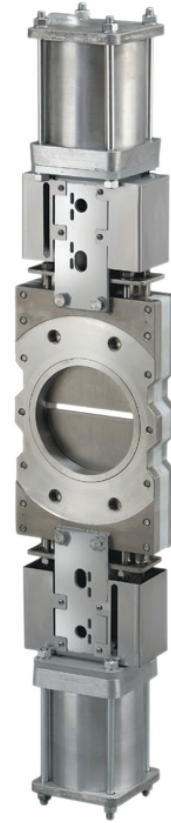

## STANDARD PARTS LIST

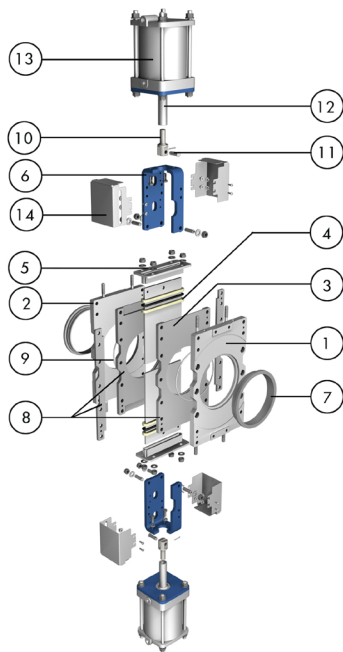

Part	Description
1	Body Carbon steel / AISI 316 <sup>1</sup>
2	Counterbody Carbon steel / AISI 316 <sup>1</sup>
3	Gate AISI 304 / AISI 316 <sup>1</sup>
4	Packing PTFE Impreg. Synth. Fibre (both with an EPDM o-ring)
5	Gland follower Carbon steel / AISI 316 <sup>1</sup>
6	Yoke Carbon Steel-Epoxy Coated
7	Seat rings CF8M
8	Body liner HMW Polyethylene
9	O-ring Nitrile
10	Clevis 17-4 PH
11	Pin AISI 304
12	Piston rod AISI 304
13	Cylinder Aluminium
14	Gate guards AISI 304

<sup>1</sup> Stainless steel configuration

## DESIGN FEATURES

### Body

Cast or fabricated two-part bolted body, internally machined, with reinforcing ribs in larger diameters for extra body strength. The body is internally lined with HMW Polyethylene that provides an optimum guiding and sliding surface for the two gates when traveling. For additional safety, the port includes two stainless steel reinforced rings. Full port design for higher flow capacity and minimal pressure drop. When the valve is in the open position, both gates are retracted into the body, assuring full flow. When the gates close, they push back into the media the fluid and contaminants that might have accumulated within the body

### Gate

Oversized stainless steel gates. Gates are polished on both sides to avoid jamming and to ensure a greater seal between the gate with both packing and seat. Special abrasion resistant materials and/or thickness can be used on request

### Stem (Fig.1)

The standard stainless steel stem offers a long corrosion resistant life. For those pneumatic actuated valves, stem linkage is provided by means of a stainless steel coupling and a pin

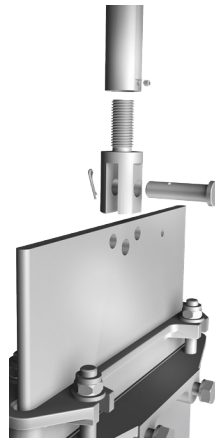

Fig.1

### Packing

Double stuffing box with several layers of braided PTFE impregnated synthetic fibre plus an EPDM o-ring, with an easy access and adjusting packing gland ensuring a tight seal. Long-life braided packing is available in a wide range of materials.

### Yoke or actuator support

Made of Epoxy coated steel (stainless steel available on request). Compact design makes it extremely robust even under the most severe conditions

### Epoxy coating

The Epoxy coating on all ORBINOX cast iron and carbon steel valve bodies and components is electrostatically applied making the valves to be corrosion resistant with a high quality finished surface. The ORBINOX standard colour is RAL-5015 blue

### Gate safety protection

ORBINOX automated valves are provided with gate guards in accordance with EU Safety Standards. The design feature prevents any objects from getting caught accidentally while the gate is moving. \*ONLY IN EUROPE

## OTHER OPTIONS

### Other materials of construction

Ductile iron, carbon steel, special stainless steels (Duplex, ...), special alloys (254SMO, Hastelloys, ...), etc.

### Fabricated valves

ORBINOX designs, produces and delivers special fabricated valves for special process conditions (big sizes and/or high pressures)

### Surface treatments

Valve components can be protected or coated for a longer life expectancy, depending on the application of the valves and the valve service conditions. At ORBINOX we can offer alternative treatments and coatings for the different valve components to improve their properties against abrasion (Stellite, hard-chroming, carbides, ...), against corrosion and against adherence

### Square/rectangular port

Modifications on port design are possible to suit customer's needs

### Accessories for pneumatic valve automation

Limit and proximity switches, solenoid valves, positioners, flow regulations, air filter units, silencers, junction boxes

## SEAT/SEAL TYPES

Material	Max.T. (°F)	Max.T. (°C)	Applications
Metal / Metal PE liner	167	75	General
On request: Metal / Metal PTFE liner	482	250	High temp./ Corrosion resistance

More details and other materials under request

## PACKING TYPES

Material	Max.T. (°F)	Max.T. (°C)	pH
PTFE impregn. synth. fiber (ST)	482	250	2-13
Braided PTFE (TH)	1112	600	0-14

All types include an elastomere O-ring (same material as seal), excluding TH

## SEAT CONFIGURATIONS/DESIGNS

Type	Features
<b>Metal / Metal</b>	<p>Used for applications with high temperature or applications where tight shutoff is not required. Two replaceable reinforced stainless steel rings protect the body. There is no elastomer seal. The four-piece liner (HMWPE as standard, PTFE or Nylon also available) of the body provides gate support to all sides ensuring gate guiding and sliding, as well as a good valve seal</p> 

## DOUBLE ACTING PNEUMATIC CYLINDER

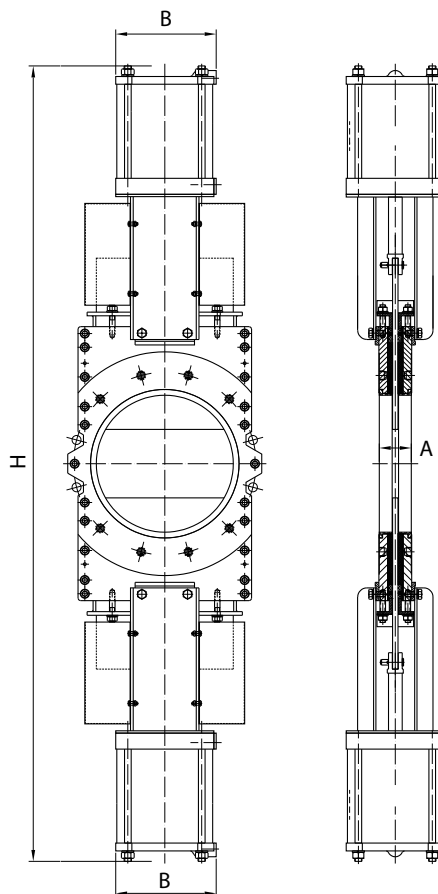

With double-acting pneumatic cylinders as standard, it is available in sizes from 4in/100mm to 24in/600mm. Single-acting pneumatic cylinders, manual overrides, fail-safe systems as well as a wide variety of pneumatic accessories for valve automation available Actuator sized for 85psi/ (6 bar) air supply, see ORBINOX Pneumatic Cylinder Catalogue for more information.

For valves installed in a horizontal position, actuator supports to plant structure is recommended





DN (in/mm)	A (in/mm)	B (in/mm)	H (in/mm)	Weight (lbs./kg.)	Connect.
4/100	1,96/50	4,53/115	34,72/882	106/48	1/4"G
5/125	1,96/50	5,51/140	36,77/934	124/56	1/4"G
6/150	2,36/60	5,51/140	42,12/1070	148/67	1/4"G
8/200	2,36/60	6,89/175	31,57/1310	176/80	1/4"G
10/250	2,75/70	8,66/220	61,49/1562	198/90	3/8"G
12/300	2,75/70	8,66/220	68,18/1732	353/160	3/8"G
14/350	3,78/96	10,90/277	77,95/1980	562/255	3/8"G
16/400	3,93/100	10,90/277	84,25/2140	750/340	3/8"G
18/450	4,17/106	15,03/382	93,31/2370	893/405	1/2"G
20/500	4,49/114	15,03/382	103,54/2630	1080/490	1/2"G
24/600	4,49/114	15,03/382	115,35/2930	1279/580	1/2"G

## FLANGE AND BOLTING DETAILS ASME B16.5, CLASS 150

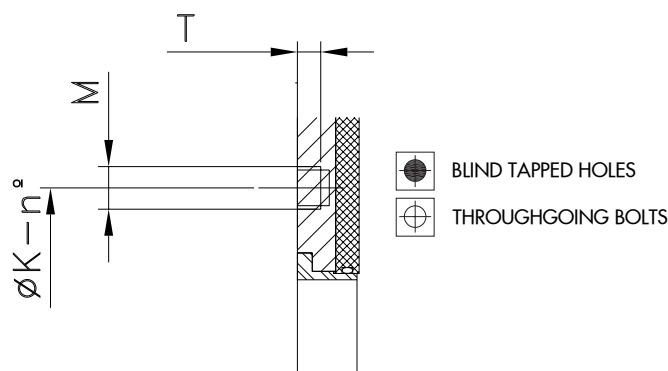
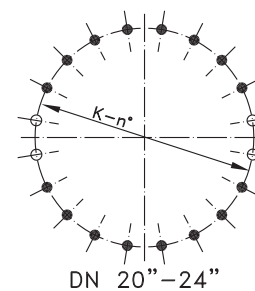
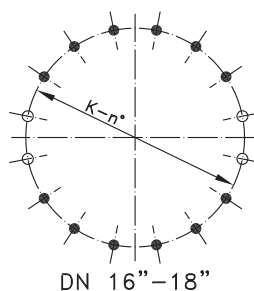
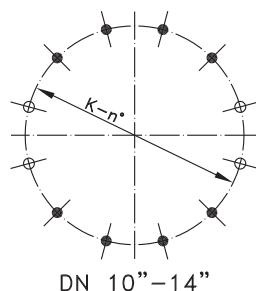
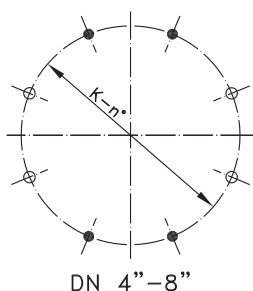
DN	K	n°	M	T	 
4"	7 1/2"	8	5/8" - 11 UNC	5/16"	4 - 4
5"	8 1/2"	8	3/4" - 10 UNC	5/16"	4 - 4
6"	9 1/2"	8	3/4" - 10 UNC	3/8"	4 - 4
8"	11 3/4"	8	3/4" - 10 UNC	3/8"	4 - 4
10"	14 1/4"	12	7/8" - 9 UNC	7/16"	8 - 4
12"	17"	12	7/8" - 9 UNC	7/16"	8 - 4
14"	18 3/4"	12	1" - 8 UNC	11/16"	8 - 4
16"	21 1/4"	16	1" - 8 UNC	13/16"	12 - 4
18"	22 3/4"	16	1 1/8" - 7 UNC	13/16"	12 - 4
20"	25"	20	1 1/8" - 7 UNC	13/16"	16 - 4
24"	29 1/2"	20	1 1/4" - 7 UNC	13/16"	16 - 4



## FLANGE AND BOLTING DETAILS EN-1092 PN10

DN	K	n°	M	T	 
100	180	8	M-16	8	4-4
125	210	8	M-16	8	4-4
150	240	8	M-20	10	4-4
200	295	8	M-20	10	4-4
250	350	12	M-20	11	8-4
300	400	12	M-20	11	8-4
350	460	16	M-20	18	12-4
400	515	16	M-24	20	12-4
450	565	20	M-24	20	16-4
500	620	20	M-24	20	16-4
600	725	20	M-27	20	16-4

